



BROOKS COUNTY  
GEORGIA

APPLICATION AND PERMIT FOR UTILITY FACILITY ENCROACHMENT  
WATER OR IRRIGATION PIPELINE CROSSING

APPLICATION IS HEREBY MADE TO BROOKS COUNTY, GEORGIA:

(UTILITY – NAME AND ADDRESS)

\_\_\_\_\_  
\_\_\_\_\_

FOR PERMISSION TO CONSTRUCT, OPERATE AND MAINTAIN THE FOLLOWING DESCRIBED UTILITY FACILITY WITHIN  
OR FROM THE RIGHT-OF-WAY OF BROOKS COUNTY ROAD NO. \_\_\_\_\_

ROAD NAME: \_\_\_\_\_

DESCRIPTION OF UTILITY: \_\_\_\_\_

\_\_\_\_\_

LOCATION: \_\_\_\_\_

\_\_\_\_\_

THE UTILITY SHALL COMPLY WITH THE MANUAL OF UNIFORM TRAFFIC CONTROL DEVICES (MUTCD), CURRENT EDITION.

THE UTILITY FACILITIES COVERED HEREBY SHALL BE INSTALLED IN ACCORDANCE WITH THE PLANS ATTACHED HERETO AND MADE A PART HEREOF. UTILITY AGREES TO COMPLY WITH AND BE BOUND BY THE APPROVED PLANS AND STANDARDS MADE A PART HEREOF BY REFERENCE. REFERENCE: HIGHWAY UTILITY CROSSING DETAIL PAGE 1 & 2, BORE AND JACK CASING 2229-1 THRU 2229-10, GENERAL PROVISIONS AND SPECIAL PROVISION.

I, THE UNDERSIGNED, DO HEREBY CERTIFY THAT I AM DULY ELECTED, OR APPOINTED, QUALIFIED, AUTHORIZED REPRESENTATIVE OF SAID UTILITY.

PERMIT REQUESTED THIS \_\_\_\_\_ DAY OF \_\_\_\_\_ 20\_\_\_\_ BY: \_\_\_\_\_  
(SIGNATURE – BLUE INK)

WITNESS TO SIGNATURE: \_\_\_\_\_  
(TYPED OR PRINTED NAME)

\_\_\_\_\_  
(TITLE & PHONE)

PERMISSION IS GRANTED FOR THE ABOVE DESCRIBED UTILITY FACILITY ENCROACHMENT IN ACCORDANCE WITH THE PLANS AND PROVISIONS HEREOF. THIS PERMIT IS TO BE STRICTLY CONSTRUED AND NO WORK OTHER THAN THAT SPECIFICALLY DESCRIBED ABOVE IS HEREBY AUTHORIZED.

PERMIT GRANTED THIS \_\_\_\_\_ DAY OF \_\_\_\_\_ 20\_\_\_\_ BY: \_\_\_\_\_  
(COUNTY ENGINEER)

## GENERAL PROVISIONS

IT IS EXPRESSLY STIPULATED THAT THIS PERMIT IS A LICENSE FOR PERMISSIVE USE ONLY AND THE PLACING OF UTILITY FACILITIES UPON PUBLIC PROPERTY PURSUANT TO THIS PERMIT SHALL NOT OPERATE TO CREATE OR VEST ANY PROPERTY RIGHT IN THE HOLDER.

WHENVER NECESSARY FOR THE CONSTRUCTION, REPAIR, IMPROVEMENTS, MAINTENANCE, SAFE AND EFFECTIVE OPERATION, ALTERATION OR RELOCATION OF ALL OR ANY PORTION OF THE HIGHWAY, AS DETERMINED BY THE COUNTY, ANY OR ALL SAID FACILITIES AND APPURTENANCES AUTHORIZED HEREUNDER SHALL BE IMMEDIATELY REMOVED FROM THE RIGHT-OF-WAY, OR RESET OR RELOCATED THEREON, AS REQUIRED BY THE COUNTY ENGINEER AND AT THE SOLE EXPENSE OF THE UTILITY UNLESS REIMBURSEMENT IS AUTHORIZED BY SEPARATE AGREEMENT. SHOULD THE UTILITY FAIL TO REMOVE OR RELOCATE ITS FACILITIES, UPON DUE NOTICE FROM THE COUNTY, THE UTILITY SHALL BE LIABLE FOR ANY EXTRAORDINARY COSTS OR DAMAGES INCURRED BY THE COUNTY AS A RESULT THEREOF.

IF THE COUNTY UNDERTAKES TO IMPROVE THIS ROAD IT SHALL BE THE RESPONSIBILITY OF THE UTILITY TO PLAN WITH THE COUNTY AND ITS CONTRACTOR A SCHEDULE WHICH WILL CLEARLY SET FORTH AT WHICH STAGE OR OPERATIONS THE UTILITY WILL BE REQUIRED TO PERFORM ANY ADJUSTMENT TO ITS FACILITIES NECESSARY TO ACCOMMODATE THE HIGHWAY IMPROVEMENTS.

DURING THE INITIAL INSTALLATION OR CONSTRUCTION OF FACILITIES AUTHORIZED BY THIS PERMIT, OR DURING ANY FUTURE REPAIR, REMOVAL, OR RELOCATION THEREOF OR ANY MISCELLANEOUS OPERATIONS, THE UTILITY SHALL, AT ALL TIMES, MAINTAIN FLAGMAN, SIGNS, LIGHTS, FLARES, BARRICADES, AND OTHER SAFETY DEVICES IN ACCORDANCE WITH THE MANUAL ON UNIFORM TRAFFIC CONTROL DEVICES, CURRENT EDITION, AND AS MAY BE NECESSARY TO PROPERLY PROTECT TRAFFIC UPON THE ROAD AND TO WARN AND SAFEGUARD THE PUBLIC AGAINST INJURY OR DAMAGE.

IT IS THE UTILITY'S RESPONSIBILITY TO VERIFY THE LIMITS OF RIGHT-OF-WAY FOR LOCATION OF THE UTILITY FACILITIES AUTHORIZED HEREBY.

NO INHERENT OR RETAINED RIGHT OR PRIVILEGE OR ANY ABUTTING PROPERTY OWNER IS AFFECTED BY THIS PERMIT NOR IS THE COUNTY RESPONSIBLE FOR ANY CLAIM WHICH MAY DEVELOP BETWEEN THE UTILITY AND ANY PROPERTY OWNER CONCERNING USE OF THE RIGHT-OF-WAY. THE UTILITY IS RESPONSIBLE FOR MAINTAINING REASONABLE ACCESS TO PRIVATE DRIVEWAYS DURING INSTALLATION OF ITS FACILITIES AND FOR RESTORATION OF DRIVEWAYS TO THE PROPERTY OWNER'S SATISFACTION.

APPROVAL OF THIS PERMIT DOES NOT CONSTITUTE APPROVAL OF DESIGN OR CONSTRUCTION DETAILS FOR THE PROPOSED UTILITY FACILITIES. THE UTILITY IS RESPONSIBLE FOR COMPLIANCE WITH ALL APPLICABLE GOVERNMENTAL CODES AND REGULATIONS.

USE OF EXPLOSIVES WITHIN THE RIGHT-OF-WAY IS PROHIBITED UNLESS APPROVED BY SEPARATE PERMIT.

THE UTILITY SHALL GIVE THE COUNTY A MINIMUM OF 24 HOURS NOTICE PRIOR TO BEGINNING ANY WORK UNDER THIS PERMIT.

THIS PERMIT SHALL BE VOID UNLESS WORK HEREUNDER IS BEGUN WITHIN TWELVE (12) MONTHS OF THE DATE OF ITS APPROVAL.

THE PROVISIONS OF THIS PERMIT ARE REGULATORY AND NOT CONTRACTUAL. NO INTEREST OR RIGHT OF A UTILITY GRANTED BY THIS PERMIT MAY BE TRANSFERRED TO ANOTHER EXCEPT BY WRITTEN CONSENT OF THE COUNTY.

THIS PERMIT MAY BE REVOKED AT THE PLEASURE OF THE COUNTY UPON THIRTY (30) DAYS WRITTEN NOTICE TO THE UTILITY.

THE INSTALLATION COVERED BY THIS PERMIT HAS BEEN COMPLETED IN ACCORDANCE WITH THE PROVISIONS OF THE PERMIT AND THE PLANS ATTACHED HERETO.

DATE: \_\_\_\_\_ SIGNED: \_\_\_\_\_  
(COUNTY ENGINEER)

## SPECIAL PROVISIONS

### UTILITY RESTORATION AND CLEANUP

The Utility Contractor or its Contractor shall plan, coordinate, and prosecute the work such that disruption to personal property and business is held to a practical minimum.

All construction areas abutting lawns and yards of residential or commercial property shall be restored promptly. Backfilling of underground facilities, ditches, and disturbed areas shall be accomplished on a daily basis as work is completed. Finishing, dressing, and grassing shall be accomplished immediately thereafter as a continuous operation within each area being constructed with emphasis placed on completing each individual yard or business frontage. Care shall be taken to provide positive drainage to avoid ponding or concentration of runoff.

Handwork, including raking and smoothing, shall be required to ensure that the removal of roots, sticks, rocks, and other debris is removed in order to provide a neat and pleasing appearance. Grassing, when in season, shall immediately follow in order to establish permanent cover at the earliest date. If grassing is not in season, proper erosion control shall be installed and maintained.

The County Engineer shall be authorized to stop all work by the Utility or its Contractor when restoration and cleanup are unsatisfactory and to require appropriate remedial measures.

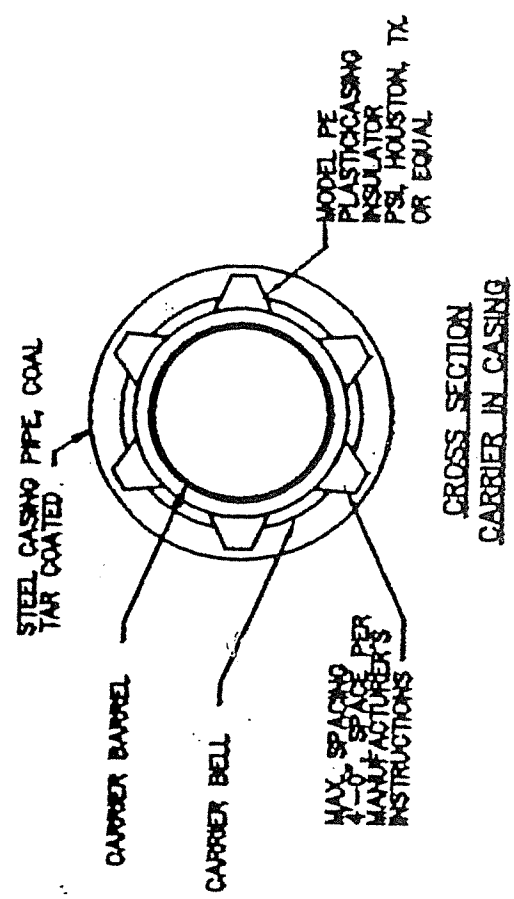

# HIGHWAY UTILITY CROSSING DETAIL

N.T.S.  
PAGE 2

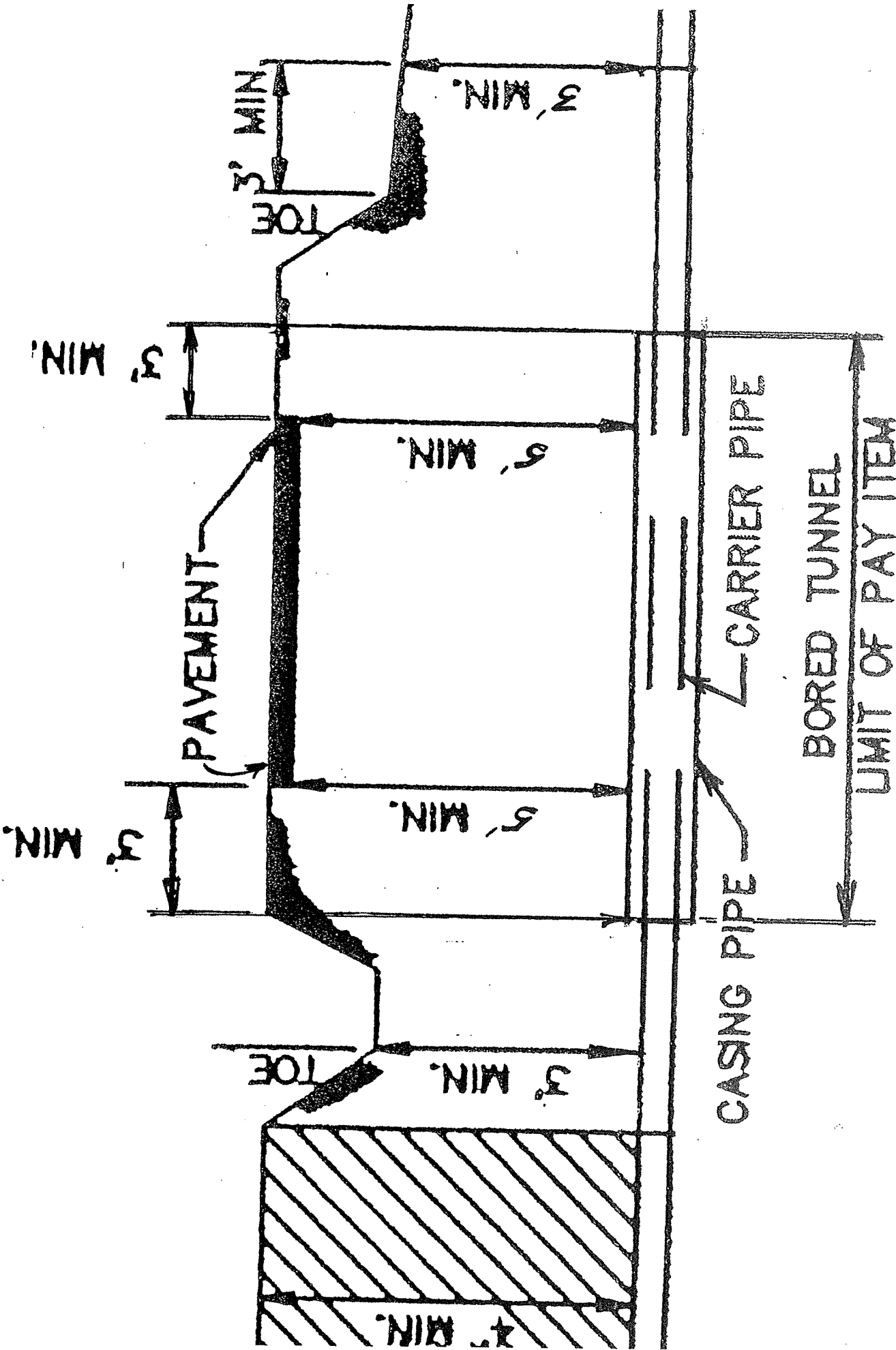

HIGHWAY UTILITY CROSSING DETAIL

N.T.S.  
PAGE 1

**PART 1 GENERAL****1.01 SCOPE**

- A. The work covered by this Section includes furnishing all labor, materials and equipment required to bore and jack casings and to properly complete pipeline construction as described herein and/or shown on the Drawings.
- B. General: Supply all materials and perform all work in accordance with applicable American Society for Testing and Materials (ASTM), American Water Works Association (AWWA), American National Standards Institute (ANSI) or other recognized standards. Latest revisions of all standards are applicable. If requested by the County, submit evidence that manufacturer has consistently produced products of satisfactory quality and performance over a period of at least two years.

**1.02 SUBMITTALS**

- A. Submit shop drawings, product data and experience.
- B. Material Submittals: The Contractor shall provide shop drawings and other pertinent specifications and product data as follows:
  - 1. Shop drawings for casing pipe showing sizes and connection details.
  - 2. Casing Spacers.
- C. Experience Submittals: Boring and jacking casings is deemed to be specialty contractor work. If the Contractor elects to perform the work, the Contractor shall provide evidence as required by the General Conditions. A minimum of five continuous years of experience in steel casing construction is required of the casing installer. Evidence of this experience must be provided with the shop drawings for review by the *COUNTY*.

**1.03 STORAGE AND PROTECTION**

All materials shall be stored and protected in accordance with the manufacturer's recommendations and as approved by the

## BORE AND JACK CASINGS

02229-2

### PART 2 PRODUCTS

#### 2.01 MATERIALS AND CONSTRUCTION

- A. Casing for Pipe Greater than 3 Inches in Diameter
1. The casing shall be new and unused pipe. The casing shall be made from steel plate having a minimum yield strength of 35,000 psi. The steel plate shall also meet the chemical requirements of ASTM A 36.
  2. The thicknesses of casing shown in paragraph B. below are minimum thicknesses. Actual thicknesses shall be determined by the casing installer, based on an evaluation of the required forces to be exerted on the casing when jacking. Any buckling of the casing due to jacking forces shall be repaired at no additional cost.
  3. The diameters of casing shown in paragraph B. below and shown on the Drawings are minimum. Larger casings, with the County's approval, may be provided at no additional cost to the *County*, for whatever reasons the Contractor may decide, whether casing size availability, line and grade tolerances, soil conditions, etc.
  4. Casing Sizes

UNDER RAILROADS			
Pipe Diameter, inches	Casing Diameter, inches	Wall Thickness, inches	
		Coated	Uncoated
6	14	0.250	0.282
8	18	0.250	0.313
10	20	0.281	0.344
12	22	0.312	0.375

<b>UNDER HIGHWAYS</b>		
<b>Pipe Diameter, inches</b>	<b>Casing Diameter, inches</b>	<b>Wall Thickness, inches</b>
6	12	0.250
8	16	0.250
10	16	0.250
12	18	0.250

- B. Casing for Pipe Less than or Equal to 3 Inches in Diameter: Casing shall be polyvinyl chloride pipe which has a minimum wall thickness equal to Schedule 80.
- C. Casing Spacers: Casing spacers shall meet one of the following requirements:
1. Casing spacers shall be flanged, bolt-on style with a two-section stainless steel shell lined with a PVC liner, minimum 0.09-inch thick also having a hardness of 85-90 durometer. Runners shall be attached to stainless steel risers which shall be properly welded to the shell. The height of the runners and risers shall be manufactured such that the pipe does not float within the casing. Casing spacers shall be Cascade Waterworks Manufacturing Company or Advanced Products & Systems, Inc.
  2. Casing spacers shall be a two-section, flanged, bolt on style constructed of heat fused PVC coated steel, minimum 14 gauge band and 10 gauge risers, with 2-inch wide glass reinforced polyester insulating skids, heavy duty PVC inner liner, minimum 0.09-inch thick having a hardness of 85-90 durometer, and all stainless steel or cadmium plated hardware shall be Pipeline Seal and Insulator, Inc.
- D. Carrier Pipe: Carrier pipes shall meet requirements as specified in these Specifications.

## **2.02 EQUIPMENT**

- A. A cutting head shall be attached to a continuous auger mounted inside the casing pipe.
- B. On casing pipe for gravity sewer over 60 feet in length, the installation equipment shall



## BORE AND JACK CASINGS

---

02229-4

include a steering head and a grade indicator.

- C. The steering head shall be controlled manually from the bore pit. The grade indicator shall consist of a water level attached to the casing which would indicate the elevation of the front end of the casing or some other means for grade indication approved by the *COUNTY*

### PART 3 EXECUTION

#### 3.01 GENERAL

- A. Interpretation of soil investigation reports and data, investigating the site and determination of the site soil conditions prior to bidding is the sole responsibility of the Contractor. Any subsurface investigation by the Bidder or Contractor must be approved by the appropriate authority having jurisdiction over the site.
- B. Casing construction shall be performed so as not to interfere with, interrupt or endanger roadway surface and activity thereon, and minimize subsidence of the surface, structures, and utilities above and in the vicinity of the casing. Support the ground continuously in a manner that will prevent loss of ground and keep the perimeters and face of the casing, passages and shafts stable. The Contractor shall be responsible for all settlement resulting from casing operations and shall repair and restore damaged property to its original or better condition at no cost *TO THE COUNTY,*
- C. Face Protection: The face of the excavation shall be protected from the collapse of the soil into the casing.
- D. Casing Design: Design of the bore pit and required bearing to resist jacking forces are the responsibility of the Contractor. The excavation method selected shall be compatible with expected ground conditions. The lengths of the casing shown on the Drawings are the minimum lengths required. The length of the casing may be extended for the convenience of the Contractor, at no additional cost. . Due to restrictive right-of-way and construction easements, boring and jacking casing lengths less than the nominal 20 foot length may be necessary.
- E. Highway Crossings
  - 1. The Contractor shall be held responsible and accountable for the coordinating and scheduling of all construction work within the highway right-of-way.
  - 2. Work along or across the highway department rights-of-way shall be subject to inspection by such highway department.

3. All installations shall be performed to leave free flows in drainage ditches, pipes, culverts or other surface drainage facilities of the highway, street or its connections.
4. No excavated material or equipment shall be placed on the pavement or shoulders of the roadway without the express approval of the highway department.
5. In no instance will the Contractor be permitted to leave equipment (trucks, backhoes, etc.) on the pavement or shoulder overnight. Construction materials to be installed, which are placed on the right-of-way in advance of construction, shall be placed in such a manner as not to interfere with the safe operation of the roadway.
6. The Contractor shall be responsible for providing the *COUNTY* sufficient information to obtain a blasting permit in a timely manner.

F. Railroad Crossings

1. The Contractor shall secure permission from the Railroad to schedule work so as not to interfere with the operation of the Railroad.
2. Additional insurance is required for each railroad crossing. The Contractor shall furnish the Railroad with such additional insurance as may be needed, cost of the same shall be borne by the Contractor.
3. All work on the Railroad right-of-way, including necessary support of tracks, safety of operations and other standard and incidental operation procedures may be under the supervision of the appropriate authorized representative of the Railroad affected and any decisions of this representative pertaining to construction and/or operations shall be final and construction must be governed by such decisions.
4. If, in the opinion of the Railroad, it becomes necessary to provide flagging protection, watchmen or the performance of any other work in order to keep the tracks safe for traffic, the Contractor shall coordinate such work and shall reimburse the Railroad, in cash, for such services, in accordance with accounting procedures agreed on by the Contractor and affected Railroad before construction is started.
5. No blasting shall be permitted within the Railroad right-of-way.

**3.02 GROUNDWATER CONTROL**

- A. The Contractor shall control the groundwater throughout the construction of the casing.
- B. Methods of dewatering shall be at the option and responsibility of the Contractor. Maintain close observation to detect settlement or displacement of surface facilities due to dewatering. Should settlement or displacement be detected, notify the *COUNTY* immediately and take such action as necessary to maintain safe conditions and prevent damage.
- C. When water is encountered, provide and maintain a dewatering system of sufficient capacity to remove water on a 24 hour basis keeping excavations free of water until the backfill operation is in progress. Dewatering shall be performed in such a manner that removal of soil particles is held to a minimum. Dewater into a sediment trap and comply with requirements specified.

**3.03 SAFETY**

- A. Provide all necessary bracing, bulkheads and shields to ensure complete safety to all traffic, persons and property at all times during the work. Perform the work in such a manner as to not permanently damage the roadbed or interfere with normal traffic over it.
- B. Observe all applicable requirements of the regulations of the authorities having jurisdiction over this site. Conduct the operations in such a manner that all work will be performed below the level of the roadbed.
- C. Perform all activities in accordance with the Occupational Safety and Health Act of 1970 (PL-596), as amended, applicable regulations of the Federal Government, OSHA 29CFR 1926 and applicable criteria of ANSI A10.16-81, "Safety Requirements for Construction of Tunnel Shafts and Caissons".

**3.04 BORING AND JACKING**

- A. Shaft
  - 1. Conduct boring and jacking operations from a shaft excavated at one end of the section to be bored. Where conditions and accessibility are suitable, place the shaft on the downstream end of the bore.
  - 2. The shaft shall be rectangular and excavated to a width and length required for ample working space. If necessary, sheet and shore shaft properly on all sides.

Shaft sheeting shall be timber or steel piling of ample strength to safely withstand all structural loadings of whatever nature due to site and soil conditions. Keep preparations dry during all operations. Perform pumping operations as necessary.

3. The bottom of the shaft shall be firm and unyielding to form an adequate foundation upon which to work. In the event the shaft bottom is not stable, excavate to such additional depth as required and place a gravel sub-base or a concrete sub-base if directed by the *COUNTY* due to soil conditions.

B. Jacking Rails and Frame

1. Set jacking rails to proper line and grade within the shaft. Secure rails in place to prevent settlement or movement during operations. The jacking rails shall cradle and hold the casing pipe on true line and grade during the progress of installing the casing.
2. Place backing between the heels of jacking rails and the rear of the shaft. The backing shall be adequate to withstand all jacking forces and loads.
3. The jacking frame shall be of adequate design for the magnitude of the job. Apply thrust to the end of the pipe in such a manner to impart a uniformly balanced load to the pipe barrel without damaging the joint ends of the pipe.

C. Boring and jacking of casing pipes shall be accomplished by the dry auger boring method without jetting, sluicing or wetboring.

D. Auger the hole and jack the casing through the soil simultaneously.

E. Bored installations shall have a bored-hole diameter essentially the same as the outside diameter of the casing pipe to be installed.

F. Execute boring ahead of the casing pipe with extreme care, commensurate with the rate of casing pipe penetration. Boring may proceed slightly in advance of the penetrating pipe and shall be made in such a manner to prevent any voids in the earth around the outside perimeter of the pipe. Make all investigations and determine if the soil conditions are such as to require the use of a shield.

G. As the casing is installed, check the horizontal and vertical alignment frequently. Make corrections prior to continuing operation. For casing pipe installations over 100 feet in length, the auger shall be removed and the alignment and grade checked at minimum intervals of 60 feet.

## **BORE AND JACK CASINGS**

---

02229-8

- H. Any casing pipe damaged in jacking operations shall be repaired, if approved by the *COUNTY*, or removed and replaced at Contractor's own expense.
- I. Lengths of casing pipe, as long as practical, shall be used except as restricted otherwise. Joints between casing pipe sections shall be butt joints with complete joint penetration, single groove welds, for the entire joint circumference, in accordance with AWS recommended procedures. Prior to welding the joints, the Contractor shall ensure that both ends of the casing sections being welded are square.
- J. The Contractor shall prepare a contingency plan which will allow the use of a casing lubricant, such as bentonite, in the event excessive frictional forces jeopardize the successful completion of the casing installation.
- K. Once the jacking procedure has begun, it should be continued without stopping until completed, subject to weather and conditions beyond the control of the Contractor.
- L. Care shall be taken to ensure that casing pipe installed by boring and jacking method will be at the proper alignment and grade.
- M. The Contractor shall maintain and operate pumps and other necessary drainage system equipment to keep work dewatered at all times.
- N. Adequate sheeting, shoring and bracing for embankments, operating pits and other appurtenances shall be placed and maintained to ensure that work proceeds safely and expeditiously. Upon completion of the required work, the sheeting, shoring and bracing shall be left in place, cut off or removed, as designated by the *COUNTY*.
- O. Trench excavation, all classes and type of excavation, the removal of rock, muck, debris, the excavation of all working pits and backfill requirements of *THE COUNTY* are included under this Section.
- P. All surplus material shall be removed from the right-of-way and the excavation finished flush with the surrounding ground.
- Q. Grout backfill shall be used for unused holes or abandoned pipes.

### **3.05 FREE BORING**

- A. Where the Drawings indicate a pipeline is to be installed by boring without casing, the Contractor shall construct the crossing by the free bore method. The free bore method shall be accomplished by the dry auger boring method without jetting, sluicing, wet boring, or by "punching".

- B. The diameter of the free bore shall not exceed the pipe bell outside diameter or the pipe barrel outside diameter plus 1-inch, whichever is greater.
- C. Free boring, where indicated on the Drawings, is to be performed at the Contractor's option. The Contractor may choose to construct the crossing by the conventional bore and jack casing methodology.
- D. The Contractor shall be responsible for any settlement of the roadway caused by the free bore construction activities.
- E. If the Contractor elects to free bore, and an acceptable installation does not result for any reason, the Contractor shall install a casing pipe by the bore and jack method.

### 3.06 VENTILATION AND AIR QUALITY

Provide, operate and maintain for the duration of casing project a ventilation system to meet safety and OSHA requirements.

### 3.07 ROCK EXCAVATION

- A. In the event that rock is encountered during the installation of the casing pipe which, in the opinion of the *County*, cannot be removed through the casing, the *County* may authorize the Contractor to complete the crossing by a method established in a change order.
- B. At the Contractor's option, the Contractor may continue to install the casing and remove the rock through the casing at no additional cost.

### 3.08 INSTALLATION OF PIPE

- A. After construction of the casing is complete, and has been accepted by the *County*, install the pipeline in accordance with the Drawings and Specifications.
- B. Check the alignment and grade of the casing and prepare a plan to set the pipe at proper alignment, grade and elevation, without any sags or high spots.
- C. The carrier pipe shall be held in the casing pipe by the use of casing spacers sized to limit radial movement to a maximum of 1-inch. Provide a minimum of one casing spacer per nominal length of pipe. Casing spacers shall be attached to the pipe at maximum 18 to 20 foot intervals.
- D. Close the ends of the casing with 4-inch brick walls or seal ends with one-piece

## **BORE AND JACK CASINGS**

---

**02229-10**

synthetic rubber especially formulated for sealing casing/carrier pipe.

### **3.09 SHEETING REMOVAL**

Remove sheeting used for shoring from the shaft and off the job site. The removal of sheeting, shoring and bracing shall be done in such a manner as not to endanger or damage either new or existing structures, private or public properties and also to avoid cave-ins or sliding in the banks.

**END OF SECTION**